



**AVERY  
DENNISON**

Fastener  
Solutions

# **34" Extra Heavy Duty Cable Ties Marketing Specifications**

For the following part numbers:

10049-0

10050-0

May 19, 2026

# AVERY DENNISON MARKETING SPECIFICATION

## HISTORY

THE SUBJECT MATTER DISCLOSED HEREIN EMBODIES PROPRIETARY INFORMATION WHICH IS THE CONFIDENTIAL PROPERTY OF THE AVERY DENNISON CO. NONE OF WHICH SHALL BE COPIED, REPRODUCED, DISCLOSED TO OTHERS, PUBLISHED OR USED IN WHOLE OR IN PART, FOR ANY PURPOSE OTHER THAN THAT FOR WHICH IT IS BEING MADE AVAILABLE WITHOUT THE EXPRESS ADVANCE WRITTEN PERMISSION OF A DULY AUTHORIZED AGENT OF THE COMPANY. THIS DOCUMENT IS THE PROPERTY OF THE AVERY DENNISON CO. AND IS TO BE RETURNED TO THE COMPANY ON DEMAND.

REV.	DATE	DESCRIPTION
H	07.02.19	UPDATED TO NEW FORMAT; mm DIMS ARE PRIMARY DIMS; -0 ADDED TO PART NUMBER; DIM 1 CHANGED TO BE TAKEN FROM BASE OF HEAD
J	04.30.26	REMOVED UL LOGO PER ECO F4198

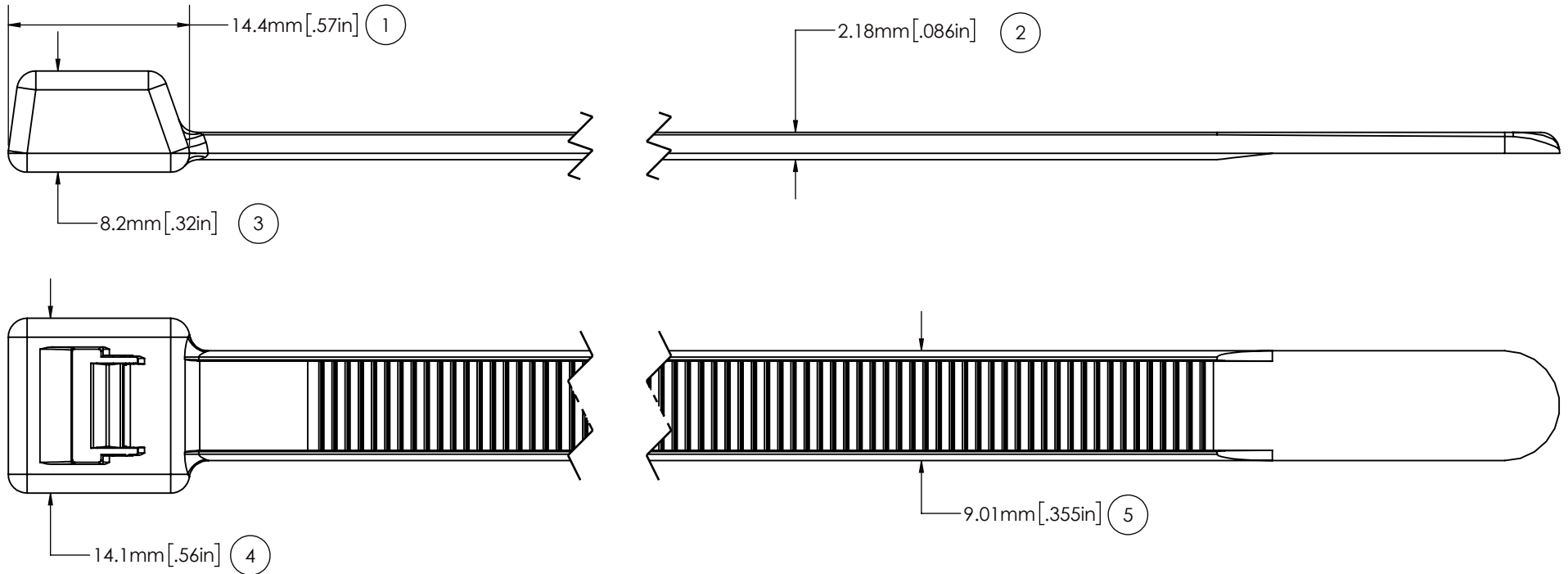

NOTES:  
1. SPECIAL CHARACTERISTICS ARE NOTED BY A TRIANGLE (Δ)

⑥	Δ FLAMMABILITY RATING:	HB RATED PER FMVSS302
⑦	Δ TENSILE STRENGTH:	175 LBF / 778N MIN.
	WEIGHT:	17.5g
	BUNDLE DIAMETER:	∅ 6.4mm TO ∅ 254mm
	TOOL:	10256-0- EXTRA HEAVY DUTY TOOL OR HAND APPLIED
	TOOL TENSION SETTING:	6 - 8
	PACKAGING:	50 PACKS IN SEALED BAG

<b>APPROVALS:</b>	ENG. <sup>R</sup> APPR.	<i>Parth Patel</i>	04.30.26
	Q.A. APPR.	<i>Abraham Rocha</i>	04.30.26

SPECIFIED TOLERANCES ARE:	
.XX ± .03 INCHES	.X ± .7 mm
.XXX ± .010 INCHES	.XX ± .25 mm
ANGULAR: ± 2°	

MATERIAL	<b>NYLON 6/6, WEATHER RESISTANT</b>
COLOR	<b>BLACK</b>

 <b>AVERY DENNISON</b> <small>FASTENER DIVISION FITCHBURG, MA 01420 U.S.A. TEL. 1-800-225-5913 FAX. 978-353-8157</small>	DESCRIPTION	34in. CABLE TIE, EXTRA HEAVY DUTY
	STOCK NO.	<b>10050-0</b>
	REV.	<b>J</b>

# AVERY DENNISON MARKETING SPECIFICATION

## HISTORY

THE SUBJECT MATTER DISCLOSED HEREIN EMBODIES PROPRIETARY INFORMATION WHICH IS THE CONFIDENTIAL PROPERTY OF THE AVERY DENNISON CO. NONE OF WHICH SHALL BE COPIED, REPRODUCED, DISCLOSED TO OTHERS, PUBLISHED OR USED IN WHOLE OR IN PART, FOR ANY PURPOSE OTHER THAN THAT FOR WHICH IT IS BEING MADE AVAILABLE WITHOUT THE EXPRESS ADVANCE WRITTEN PERMISSION OF A DULY AUTHORIZED AGENT OF THE COMPANY. THIS DOCUMENT IS THE PROPERTY OF THE AVERY DENNISON CO. AND IS TO BE RETURNED TO THE COMPANY ON DEMAND.

REV.	DATE	DESCRIPTION
J	04.30.26	MADE DRAWINGS IN SOLIDWORKS. REMOVED UL LOGO PER ECO F4198

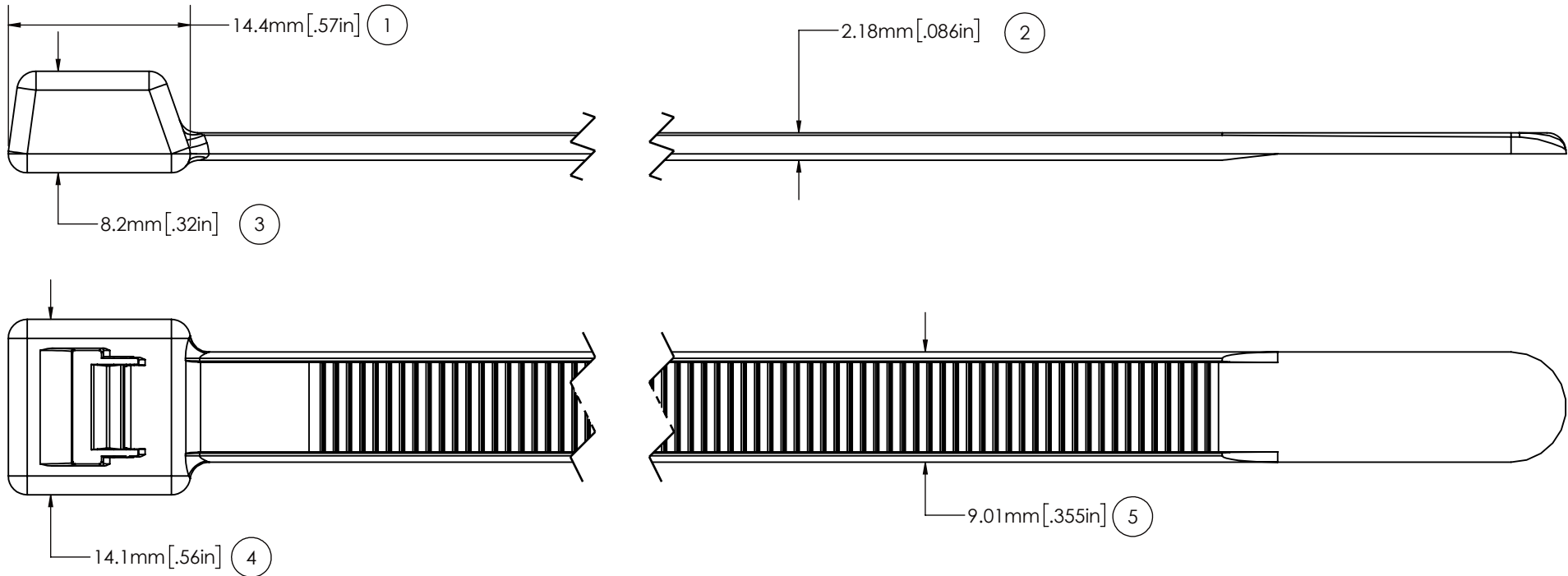

NOTES:  
1. SPECIAL CHARACTERISTICS ARE NOTED BY A TRIANGLE (Δ )

⑥	Δ TENSILE STRENGTH:	175 LBF / 778N MIN.	<b>APPROVALS:</b>	ENG. <sup>R</sup> APPR. <i>Parth Patel</i>	04.30.26		<b>AVERY DENNISON</b>	FASTENER DIVISION FITCHBURG, MA 01420 U.S.A. TEL. 1-800-225-5913 FAX. 978-353-8157	
	WEIGHT:	17.5g		Q.A. APPR. <i>Abraham Rocha</i>	04.30.26				
	BUNDLE DIAMETER:	∅ 6.4mm TO ∅ 254mm	<b>SPECIFIED TOLERANCES ARE:</b>		<b>MATERIAL</b>		<b>NYLON 6/6</b>		
	TOOL:	10256-0- EXTRA HEAVY DUTY TOOL OR HAND APPLIED	.XX ± .03 INCHES	.X ± .7 mm	<b>COLOR</b>		<b>NATURAL</b>		
	TOOL TENSION SETTING:	6 - 8	.XXX ± .010 INCHES	.XX ± .25 mm	<b>DESCRIPTION</b>		34in. CABLE TIE, EXTRA HEAVY DUTY		
PACKAGING:	50 PACKS IN SEALED BAG	<b>ANGULAR: ± 2°</b>		<b>STOCK NO.</b>		<b>10049-0</b>		<b>REV.</b>	<b>J</b>